

3021/3023 BUCKPUCK™

Wide Range LED Power Module

PRODUCT OVERVIEW

The 3021 and 3023 BuckPuck LED Power Modules are a line of true current regulated drivers for powering LEDs. The BuckPuck line of LED drivers is the ideal choice for powering all types of high-brightness and high-power LED Packages and LED arrays.

The line of BuckPuck LED drivers exhibit high efficiency and require no external current limiting resistors or additional heat sinking for operation. A fast response current-sensing circuit makes the 3021 and 3023 ideal for applications where flashing or strobe operation of the LED(s) is required.

A wide range of options are available including external dc analog voltage intensity control, TTL/CMOS logic level on/off control ("E" Version), and set-and-forget internal current limiting ("I" Version). The standard units are fully potted in an extremely small form factor* and are provided with a simple 7 pin SIP connection for through-hole PCB mounting (3021) or 6" 24AWG Colored Leads (3023).

The 3021 and 3023's built-in regulated 5V reference (E and I versions) can provide output to power logic circuitry or microprocessor, eliminating the need for an additional power supply on the circuit board.



FEATURES

- ✓ DC or AC input voltage up to 32V (24VAC_{RMS})
- ✓ 350mA, 500mA, 700mA, or 1.0A constant current output*
- ✓ Extremely small form factor* (0.83"x0.83"x0.43")
- ✓ The 3021 has a simple 7-pin SIP connection for through-hole PCB mounting or use with an optional wiring harness (3021HX)
- ✓ The 3023 has permanently attached wires
- ✓ External analog/digital intensity control (TTL compatible)
- ✓ Optional external potentiometer intensity control (0-100%)
- ✓ Optional on-board trim adjustment (40-110%)
- ✓ Output short circuit protection up to 15 seconds
- ✓ Output open circuit protection
- ✓ Pulse and strobe capable (control input)
- ✓ Built-in 5V reference/output to power logic circuitry or μ Processor

TYPICAL APPLICATIONS

- ✓ Solar & Landscape Lighting
- ✓ Architectural Lighting
- ✓ Track Lighting
- ✓ Automotive & Marine Lighting
- ✓ Portable Lighting & Flashlights
- ✓ Point of Purchase Lighting
- ✓ Desk & Reading Lamps
- ✓ Signal & marker Lighting
- ✓ Flashing & Strobe Lighting
- ✓ Cabinet & Display Case Lighting
- ✓ Sign & Channel Letters
- ✓ Much More...

MADE IN

 U. S. A.

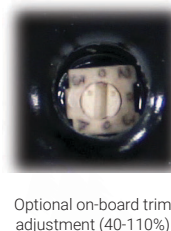
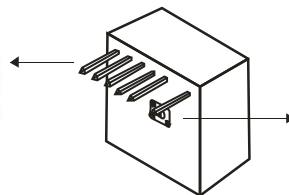
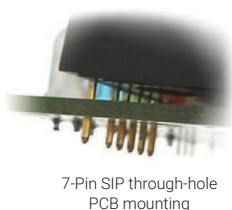

* - Custom units can be designed for OEM applications. Contact LUXdrive for more information.

3021/3023 BUCKPUCK™

Wide Range LED Power Module

Part Number Identification Table

Part Number	DC Input	AC Input	On-Board Trim	Control/immung	Connection Type
3021-D-N-xxxx	5-32V	no	no	no	7-Pin SIP (4 Pins)
3021-D-E-xxxx	7-32V	no	no	yes	7-Pin SIP (6 Pins)
3021-D-I-xxxx	7-32V	no	yes	yes	7-Pin SIP (6 Pins)
3023-D-N-xxxx	5-32V	no	no	no	4 Wires
3023-D-E-xxxx	7-32V	no	no	yes	6 Wires
3023-D-E-xxxxP	7-32V	no	no	yes	6 Wires
3021-A-N-xxxx	no	7-24V _{RMS}	no	no	7-Pin SIP (4 Pins)
3021-A-E-xxxx	no	7-24V _{RMS}	no	yes	7-Pin SIP (6 Pins)
3021-A-I-xxxx	no	7-24V _{RMS}	yes	yes	7-Pin SIP (6 Pins)
3023-A-N-xxxx	no	7-24V _{RMS}	no	no	4 Wires

XXXX - Output current rating in milliamperes (mA): 350, 500, 700, 1000 or special order factory custom rating

Absolute Maximum Ratings

Input Voltage, DC Model	32V _{DC}
Input Voltage, AC Model	24V _{RMS}
Output Voltage	32V _{DC}
Control Pin Voltage	10V
Reference regulator current (5V _{DC}) Output	20mA

Typical Characteristics

Output tolerance (within specified temp. range)	±10%
Efficiency	95%
Input Voltage Minimum	5V _{DC} (N), 7V _{DC} (E or I), 7V _{RMS}
Input Margin (350mA unit1, add to LED V _f MAX)	2.5V _{DC} , 4V _{RMS}

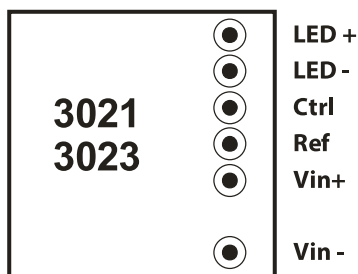

Figure 1. Bottom view Pinout of the 3021/3023 BuckPuck

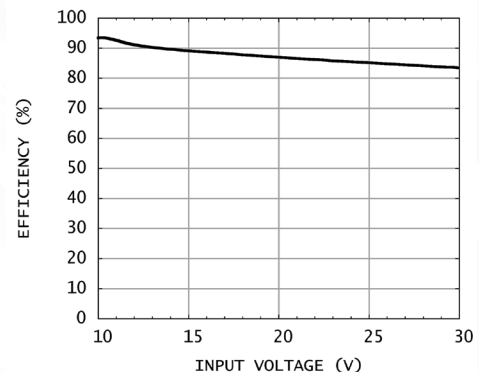

Figure 2. Efficiency vs. Vin

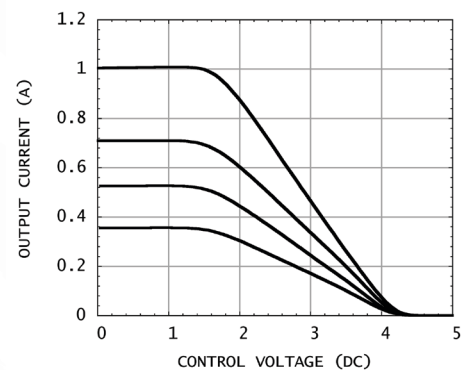

Figure 3. Output current vs. control voltage

1 - Margin increases with higher current units.



3021/3023 BUCKPUCK™

Wide Range LED Power Module

Absolute Maximum Ratings

Output current, 3021-x-x-350, 3023-x-x-350, 350P, 500P, 700P, 1000P	350mA ¹
Output current, 3021-x-x-500, 3023-x-x-500	500mA ¹
Output current, 3021-x-x-700, 3023-x-x-700	700mA ¹
Output current, 3021-x-x-1000, 3023-x-x-1000	1000mA ¹
Control Pin, adjustment threshold	1.65 V ±5%
Control Pin, shutoff threshold	4.2 V ±5%
Control Pin, propagation delay to output	<15 μs
Control Pin, input impedance	1.5k ohm
Reference voltage (V_{in} = 7V or greater)	5 VDC ±5% ²
Optional trim pot adjustment range	40%-110%
External pot adjustment range	0%,1-100% ²
Maximum flash frequency	10 kHz
Minimum strobe pulse width	50 μs
Output rise time	<10 μs ³
Output fall time	<350 μs ³
Quiescent current (no load or control pin high)	<4.5 mA ³
Operating temperature (Tcase)	-40+80°C
Storage temperature	-40+125°C

Application Information

Description

The 3021/3023 Wide Range LED Power Module is a high efficiency dc to dc converter which delivers a fixed output current by varying the output voltage as required to maintain the specified current . A fast response current-sensing circuit permits the unit to be used in applications where flashing or pulsing of the LEDs is required. Several options are available allowing for use with many types of LEDs and in a variety of operating modes

Fixed Current Drive

The fixed output versions of the 3021/3023 are designed to supply their rated current to one or more LED junctions. For example, a 350 mA rated unit will drive up to six white 350mA LEDs connected in series at 24VDC. Due to the nature of the buck regulator, the input voltage must always be higher than the total forward voltage drop of the LED junction(s) connected in series (2.5V for DC models, 4V for AC models). Thus, for a series string of six junctions having an average forward drop of 3.5V each, the required minimum input voltage will be 23.5VDC. A standard 24VDC power supply is a good choice for this application.

Figures 4 through 6 show 700mA and 1000mA rated units driving multiple LEDs. Note that parallel strings of LEDs can be driven directly with no additional circuitry required to ensure current sharing. The nature of the LEDs themselves will provide sufficient current sharing if the parallel strings comprise of 3 or more junctions each.

1 - Measured with single emitter; output current drops slightly with additional series junctions to limit maximum power dissipation.

2 - When $V_{in} > 7VDC$

3 - Actual value varies greatly based on input and/or output voltages. Value shown is for $V_{in} = 24VDC$ $V_{OUT} = 20VDC$ LED load. Actual values will be smaller in most applications.



3021/3023 BUCKPUCK™ Wide Range LED Power Module

Adjustable Current - On-Board Control - "I" Model

Where the ability to adjust the output current to an intermediate value is required, all output current ratings are available with an on-board potentiometer. This permits the output current to be varied from approximately 40% to 110% of the rated value. When measuring the output is required to determine a particular set point, the following method is recommended:

- Temporarily place a 0.1 ohm, 1% resistor in series with the LEDs.
- Read the voltage across the 0.1 ohm resistor.
- The voltage, in millivolts X 10, will equal the output current in mA.

Because there is a small, high-frequency component in the 3021/3023 output, many multi-meters may give an incorrect reading when used in the current mode. It has been found that the method described above yields a far more accurate measurement.

The potentiometers used for the on-board adjustable units are rated for a limited number of rotations (typically 100) and are intended for "set it and forget it" applications. Where frequent adjustments of output current are needed, the use of units with external adjustment capabilities is recommended.

Adjustable Current - External Control - "E" Model

Figures 10 and 11 show external adjustment configurations. Both use a 5Kohm, linear taper potentiometer. In Figure 10, the potentiometer is connected between the internal 5VDC reference (Ref) output and the control (Ctrl) input. When using this configuration, it is important that V_{in} be 7VDC or higher. Figure 11 shows the control potentiometer being powered by an external 5VDC source. When using an external power source for the potentiometer, the source ground must be common to the LED- output pin. In either configuration, connect the potentiometer such that clockwise rotation increases the resistance. Note that, because the current through the potentiometer is less than 5mA, a low power potentiometer may be used.

External On/Off Control

Where a manual on/off control is desired, the potentiometer in Figures 10 and 11 may be replaced by a pushbutton or toggle switch. The output current will be zero when the switch is closed. Figures 12 and 13 show external dimming control combined with on/off control. The circuit in Figure 13 uses a 2N3906 or equivalent PNP switching transistor.

External Pulse/Strobe Control

Figures 14 and 15 show two methods for low speed pulsing or high speed flashing operation. In Figure 14, a 5V TTL/CMOS logic signal is applied directly to the control (Ctrl) input of the 3021/3023. The output current will be zero when the control signal is high. Note that the input needs to source a minimum of 4.75VDC into a 1.5Kohm input impedance. Also, as is the case with a dc control signal, the logic input ground should be common to the LED- output terminal.

Figure 15 shows an inverted input configuration using a 2N3906 or other PNP switching transistor. In this case, a logic high will cause the output to be "on". In either configuration, the rise time of the output will be 10µsec or less. A pulse frequency up to 10kHz may be used.

Microprocessor Control

Figure 16 shows a typical interface for a Microchip PIC® or similar µcontroller. The reference output provides the operating voltage for the processor (5V at up to 20mA current).

3021/3023 BUCKPUCK™

Wide Range LED Power Module

Other Control Applications

In addition to the configurations described above, the 3021/3023 may also be driven by a D to A converter. As in the cases above, the analog control signal should have its ground common to LED-. Figure 2 shows the effective control range of the analog input signal.

Connections

In all cases, the LEDs being driven should be located as close to the 3021/3023 LED output as possible. When the use of long leads is required, use heavier gauge wire. For strobe or pulse applications, a wire length not exceeding 6" should be used to maintain accurate timing.

The power input wires/traces should also be kept short. Where DC input units are located more than 18" from the source, a 220µF, 50V capacitor should be placed across the input terminals as shown in Figure 18.

For applications where the use of header pins is inconvenient, a mating connector with 6" leads is available as an accessory, or the 3023 part number may be used, which is supplied with 6" colored leads.

- 3021HN** -Harness for "N" type (4-wire)
- 3021HE** - Harness for "E" & "I" type (6-wire)
- 3021HEP** - Harness for "E" & "I" w/pot (6-wire w/pot)

Application Figures

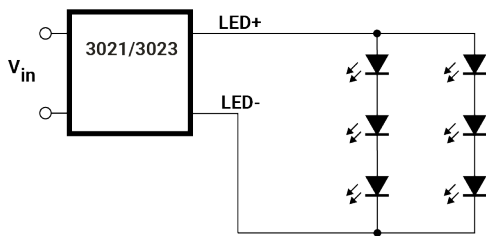

Figure 4.
700 mA unit driving 6 High Power LEDs
(VIN > 12VDC)

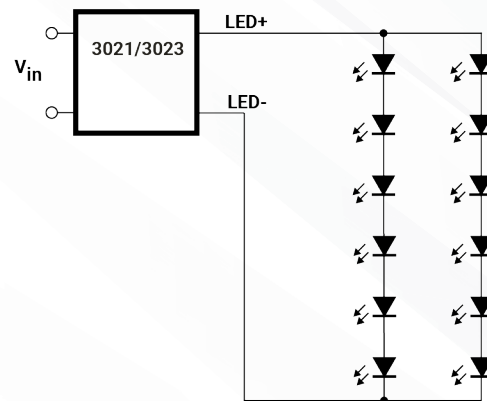

Figure 5.
700mA unit driving 12 High Power LEDs
(VIN > 24VDC)

3021/3023 BUCKPUCK™

Wide Range LED Power Module

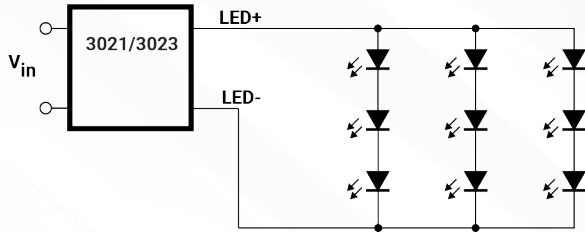

Figure 6.
1000mA unit driving nine High Power LEDs
at 1W each ($V_{IN} > 12VDC$)

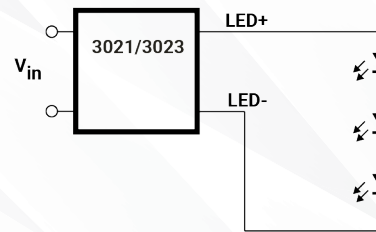

Figure 7.
1000mA unit driving three High Power LEDs
at 3W each ($V_{IN} > 12VDC$)

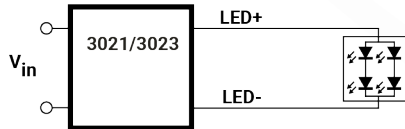

Figure 8.
700mA unit driving one Cree MC-E emitter
($V_{IN} > 8VDC$)

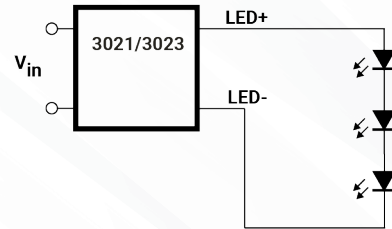

Figure 9.
700mA unit driving three High Power LEDs
at 2W each ($V_{IN} > 12VDC$)

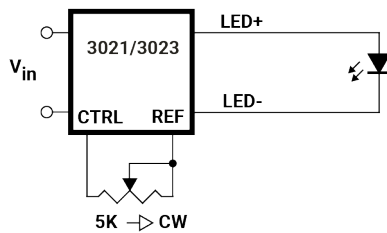

Figure 10.
External potentiometer using internal
reference

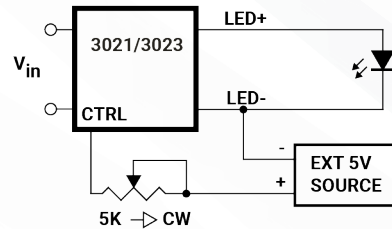

Figure 11.
External potentiometer using external voltage
source

3021/3023 BUCKPUCK™

Wide Range LED Power Module

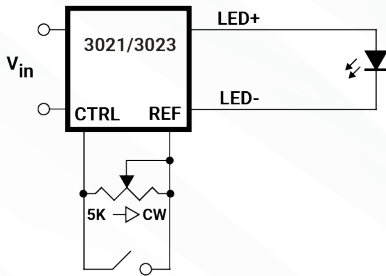

Figure 12.
External dimming plus ON/OFF control with switch closure

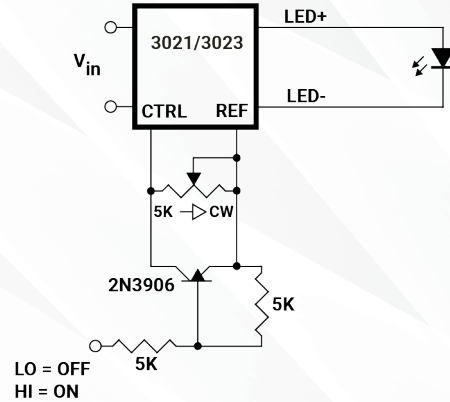

Figure 13.
External dimming plus ON/OFF control with logic level input

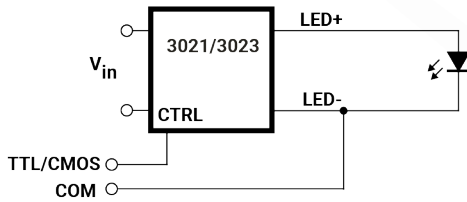

Figure 14.
Pulse/Strobe input 5V=OFF

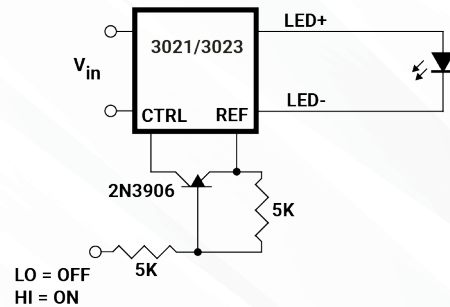

Figure 15.
Pulse/Strobe input 5V=ON

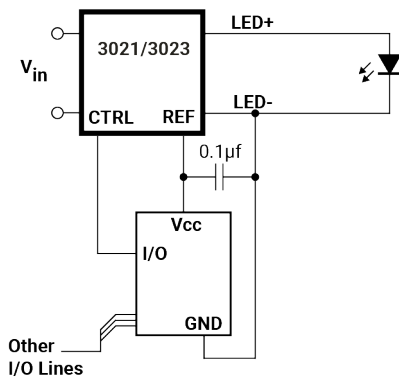

Figure 16.
Interface to PIC or other microcontroller

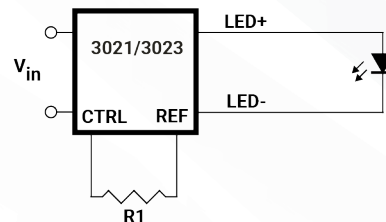
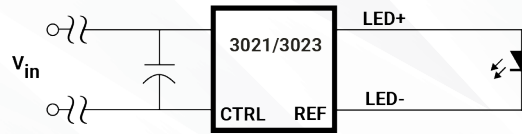

Figure 17.
Using resistor for fixed current reduction
Output is approximately: %IOUT = R1/50

3021/3023 BUCKPUCK™

Wide Range LED Power Module

Figure 18.

Place a capacitor across the input terminals when the distance to the DC power source is greater than 18 inches

Physical Dimensions

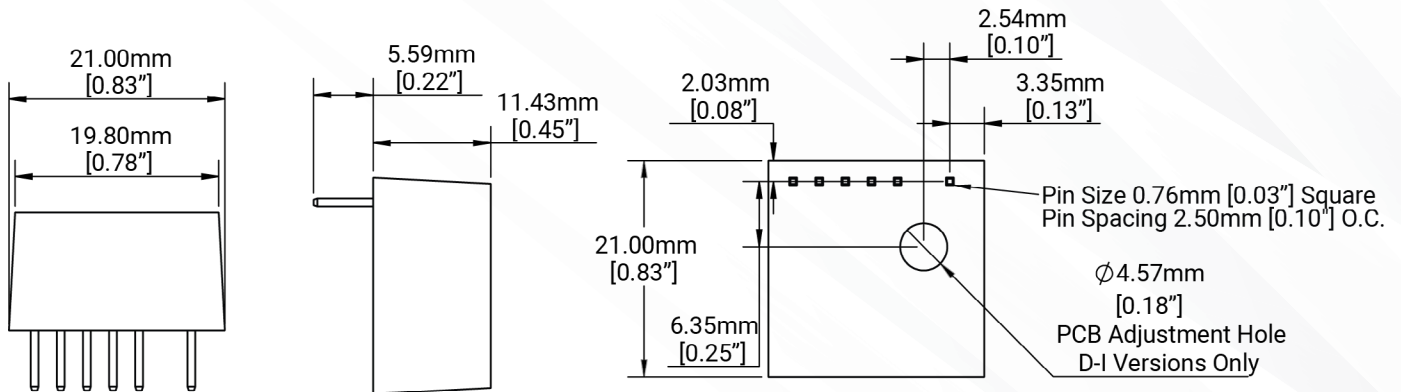

*ALL DIMENSIONS ±0.03"

3021

Recommended Clearance Envelope
Additional PCB Layout Information Available

3023
6" - 24AWG Colored Leads
